

TAYLOR STUDWELDING SYSTEMS LIMITED



OPERATING GUIDE

FOR

TYPE DA8

DRAWN ARC PISTOL

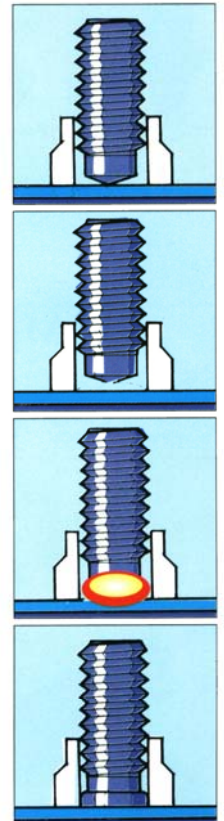

A TAYLORMADE DRAWN ARC STUDWELDING PISTOL

INDEX

PAGE No. CONTENT

3	USEFUL INFORMATION.
5	IMPORTANT SAFETY INFORMATION.
7	INTRODUCTION TO STUDWELDING.
8	SETTING UP AND WELDING.
11	EXPLODED DIAGRAMS AND PARTS LISTINGS.
17	ACCESSORIES.
21	EC DECLARATION OF CONFORMITY.

USEFUL INFORMATION

MANUFACTURERS DETAILS

**TAYLOR STUDWELDING SYSTEMS LIMITED
COMMERCIAL ROAD
DEWSBURY
WEST YORKSHIRE
WF13 2BD
ENGLAND**

**TELEPHONE : +44 (0)1924 452123
FACSIMILE : +44 (0)1924 430059
email : sales@taylor-studwelding.com
WEB : www.taylor-studwelding.com**

**SALES DIRECT TEL : +44 (0)1924 487703
TECHNICAL HELPLINE : +44 (0)1924 487701**

You may wish to record the details of your controller below as this information will help with any technical assistance you may require:

PISTOL SERIAL No.	
DATE PURCHASED.	

PURPOSE AND CONTENT OF THIS GUIDE

This guide has been written for :

- The personnel of the end-user responsible for the installation and maintenance of the controller.
- The operator of the welding controller.

This guide contains information relating to :

- Installation and connection.
- Operation.
- Technical specifications and parameters.
- Spare parts.

USEFUL INFORMATION

FURTHER INFORMATION

Should you require additional technical information, please contact us directly (details on previous page) or our local agent / distributor (details of agents etc. can be obtained from us).

This guide contains important information which is a pre-requisite for safe Operation of the equipment. The operating personnel must be able to consult this guide when necessary. In the interests of safety, make this guide available to your personnel in good time.

If the equipment is sold / passed on, please hand over this manual to the new owner and if possible please inform us of the name and address of the new owner, in case we need to contact him regarding the safety of the machine.



PLEASE READ THIS GUIDE CAREFULLY BEFORE INSTALLING OR OPERATING THE CONTROLLER.



PLEASE OBSERVE CAREFULLY ALL SAFETY PROCEDURES/INSTRUCTIONS.



DUE TO THE POWER REQUIREMENTS AND ELECTROMAGNETIC EMISSIONS PRODUCED DURING NORMAL USE, THIS MACHINE MUST ONLY BE OPERATED IN AN INDUSTRIAL ENVIRONMENT.



THIS MACHINE OPERATES FROM A MAINS SUPPLY OF 380/415V AC @ 50/60 Hz



NEVER REMOVE ANY PORTION OF THE UNIT HOUSING WITHOUT FIRST ISOLATING THE CONTROLLER FROM THE MAINS ELECTRICAL SUPPLY.



NEVER OBSTRUCT THE UNDERSIDE, FRONT OR REAR PANELS AS THIS MAY CAUSE THE UNIT TO OVERHEAT DURING OPERATION.

IMPORTANT SAFETY INFORMATION !

PROTECT YOURSELF AND OTHERS !

Read and understand these safety notes.

ELECTRICAL

No portion of the outer cover of the welding controller should be removed by anyone other than suitably qualified personnel and never whilst mains power is connected.

ALWAYS DISCONNECT THE MAINS LEAD BEFORE ATTEMPTING ANY MAINTENANCE.



BEWARE - RISK OF ELECTRIC SHOCK !

Do not use any fluids to clean electrical components as these may penetrate into the electrical system.

Installation must be according to the setting up procedure detailed on page 8 of this guide and must be in line with national, regional and local safety codes.

FIRE

During welding small particles of very hot metal are expelled. Ensure that no combustible materials can be ignited by these.

PERSONNEL SAFETY

Arc rays can burn your eyes and skin and noise can damage your hearing. Operators and personnel working in close proximity must wear suitable eye, ear and body protection.

Fumes and gases can seriously harm your health. Use the equipment only in a suitably ventilated area. If ventilation is inadequate, then appropriate fume extraction equipment must be used.

Hot metal spatter can cause fire and burns. Appropriate clothing must be worn. Clothing made from, or soiled with, combustible materials must NOT be worn.

Have a fire extinguisher nearby and know how to use it.

Magnetic fields from high currents can affect heart pacemakers or other electronically controlled medical devices. It is imperative that all personnel likely to come into the vicinity of any welding plant are warned of the possible risks before entering the area.

MAINTENANCE

All cables must be inspected regularly to ensure that no danger exists from worn or damaged insulation or from unsound electrical connections. Special note should be made of the cables close to the pistol, where maximum wear occurs. As well as producing inconsistent welds, worn cables can overheat or spark, giving rise to the risk of fire.

IMPORTANT SAFETY INFORMATION !

5. TRAINING

Use of the equipment must be limited to authorised personnel only who must be suitably trained and must have read and understood this manual. This manual must be made available to all operators at all times. Further copies of this manual may be purchased from the manufacturer. Measures must be taken to prevent the use of this equipment by unauthorised personnel.

6. INSTALLATION

Ensure that the site chosen for the equipment is able to support the weight of the equipment and that it will not fall or cause a danger in the course of its normal operation. Do not hang connecting cables over sharp edges and do not install connecting cables near heat sources or via traffic routes where people may trip over them or they may be damaged by the passage of vehicles (forklifts etc).

7. INTERFERENCE

During welding operations, intense magnetic and electrical fields are unavoidably produced and these may interfere with other sensitive Electronic equipment. As previously mentioned, all personnel wearing heart pacemakers or other electronically controlled medical devices must be kept well away from any welding operations. The welding equipment should be installed at least 5 metres away from any computer equipment to minimise any possible interaction. Note that cables carrying signals between electronic devices are also capable of picking up interference which may modify the way in which those devices function and therefore should be sited outside the 5 metre zone. Do not place objects which are sensitive to magnetism near the welding area, wristwatches, credit cards, computer disks etc. will all be rendered useless. The welding equipment, like all other welding equipment, is itself electronically sensitive and its position relative to other radiation emitting equipment (mobile phones, remote controls, motor speed controllers etc.) must be considered.

8. DISPOSAL

The equipment either wholly or any of its component parts may be disposed of as part of general industrial waste or passed to a scrap merchant. None of the components used in the manufacture are toxic, carcinogenic or harmful to health in their "as supplied" condition.

INTRODUCTION TO STUDWELDING

The Taylor Studwelding DA8 studwelding pistol when matched with an appropriate controller and earth cables is intended for precision stud welding up to 10 mm diameter reduced base studs. The pistol is lightweight, ergonomic and has been designed to operate with a minimum amount of maintenance.

The energy required to carry out the welding operation is derived from an appropriate studwelding controller.

Taylor Studwelding Systems Ltd controllers are modern, robustly designed and offer maximum reliability combined with an easy to understand operator interface.

THE PROCESS

The process of drawn arc studwelding is long established and well proven. The basic steps are as follows :

- A measured amount of weld stud protrusion is set at the welding pistol.
- Once in position, the pistol lifts the stud away from the work-piece, simultaneously striking an arc between the two.
- Both the tip of the weld stud and the surface of the work-piece melt as the arc is sustained for a pre-determined interval.
- At the completion of the pre-determined interval, the pistol returns the weld stud to the molten pool on the work-piece, thus forming a weld.

The most common and traditional drawn arc welds have a weld duration greater than 100ms and employ the use of a single use ceramic arc shield, commonly referred to as a ferrule. This ferrule helps to protect the arc during the weld and assists in formation of the final fillet. Post welding the ferrule is removed and disposed of.

It is possible to stud weld without a ferrule. This method is more commonly employed with welds having a duration of less than 100 ms and this type of weld is referred to as short cycle stud welding. Although no ferrule is employed, it is recommended practice in short cycle welding to employ a suitable shielding gas to reduce the amount of porosity in the completed weld and improve weld quality.

SETTING UP AND WELDING

As standard, the DA8 pistol comes fitted with a 30mm one piece gas cone type front end cap as shown below (fig. 1). Other front end arrangements are available for the pistol to enable the pistol to weld insulation pins (fig. 2), standard drawn arc studs (fig. 3) and long studs with gas shielding (fig. 4).

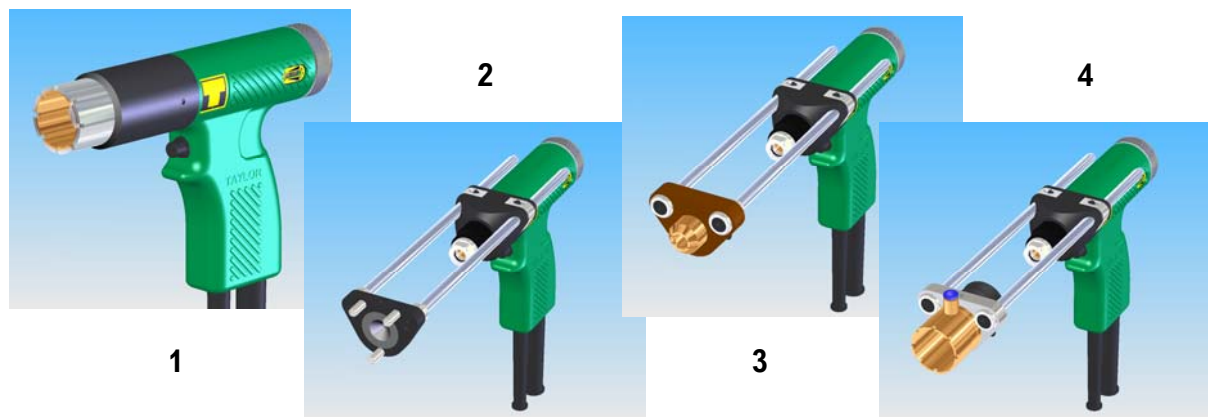

Please refer to the accessories section of this guide for information regarding the alternative front end arrangements for the pistol.

The DA8 pistol is what is commonly referred to as a “fixed lift” pistol. This is because the lift mechanism in the pistol does not include a clutch assembly.

What this means in practical terms is that although the lift can be adjusted within its operational limits, should certain parameters change from weld to weld, for example the studs being welded varying in length, this will have an effect on the amount of lift during the weld. Because of this we recommend that only properly manufactured weld studs be used to ensure repeatable weld quality.

Once you have selected the type and size of stud you wish to weld and obtained the correct chuck (see the accessories section of this guide for a list of available sizes), you will need to set up the chuck and fit it into the pistol.

On the previous page “An introduction to studwelding”, under the heading “The Process” it explains that a measured amount of stud protrusion is set at the welding pistol. This is achieved by placing the stud in the chuck and adjusting the chuck backstop to give the desired stud protrusion from the chuck. The stud protrusion will differ depending on the front end arrangement fitted to the pistol.

With the standard one-piece end cap the stud needs to be set with approx’ 3 - 4 mm protrusion as shown in the illustration here.

If standard drawn arc studs are being welded using ceramic ferrules the protrusion will need to be greater. The minimum requirement can be estimated as 1 mm + the thickness of the ferrule being used + 4 mm.

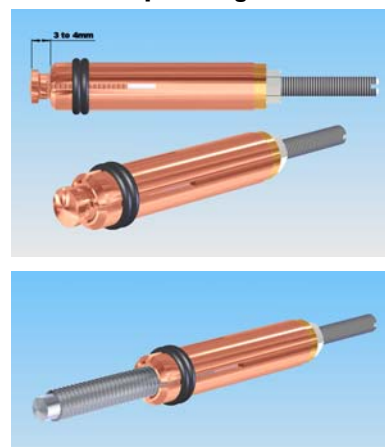

SETTING UP AND WELDING

Having set up the chuck, you are now ready to fit it into the pistol. This is achieved by inserting the chuck into the pistol and pushing it firmly home until it comes to a stop. Secure the chuck in place by tightening the chuck nut with the box key provided.

IMPORTANT! The chuck nut only needs to be gently tightened. Over-tightening may result in damage to your pistol.



If you are using the standard one-piece front end, you are now ready to set the lift and can skip the next paragraph which relates to pistols fitted with adjustable leg front end arrangements.

If you are using a pistol fitted with an adjustable leg front end arrangement you will need to set the stud protrusion by adjusting the position of the foot piece as shown in the accompanying illustration. Once the correct protrusion is set, you must ensure that the movement of the stud inside the ferrule is smooth, as any binding between the stud and ferrule will result in poor or bad welds. As can be seen in the lower illustration where the foot piece is shown transparent, the holes in the foot piece are a lot bigger than the screws fastening the foot piece to the legs. This allows the foot piece to be adjusted to remove any binding between the stud and ferrule. Once these conditions are satisfied, you are now ready to set the lift.

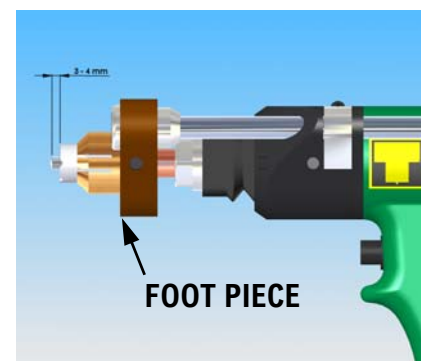

IMPORTANT!

It is necessary to check/reset the protrusion when changing stud lengths/diameters.

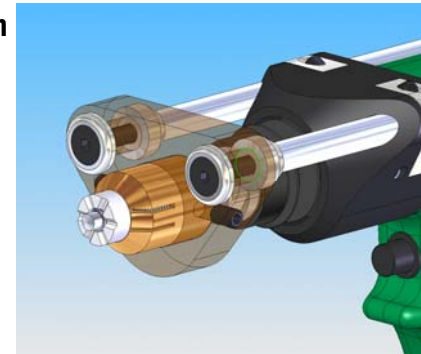

SETTING THE LIFT

Adjustment of the pistol lift is achieved by turning the rear end cap of the pistol. Clockwise rotation reduces lift and conversely anti-clockwise rotation increases lift.

NOTE! It is important that the lift setting procedure is carried out whilst the controller is switched off or the pistol is disconnected from the controller to prevent accidental firing whilst carrying out the procedure.



In order to properly adjust the lift, the pistol lift must first be zeroed. This is achieved by firstly adjusting the lift to the maximum setting. With the pistol at maximum lift and fitted with a chuck and a weld stud in place and the correct protrusion set. Take the pistol and place it in a welding position against a flat surface. This will push the tip of the weld stud back until it is level with the leading edge of the nose cone/ferrule (taking up the protrusion).

SETTING UP AND WELDING

With the pistol held firmly in this position gently turn the rear end cap adjuster clockwise until the motion becomes stiff. Further adjustment at this point should try to push the weld stud out, forcing the nose cone/ferrule away from the surface. This is the zero lift point.

You are now ready to set the required lift. To set the required lift, turn the rear end cap anti-clockwise, counting clicks on the adjuster detent. One click is equal to 0.25 mm of lift. Therefore a desired lift of 2 mm equates to 8 clicks

Once the required lift has been set, the pistol is now ready to weld and can be connected to the controller. Consult your appropriate controller operating guide for assistance in setting up the controller.

IMPORTANT!

It is necessary to check/reset the zero lift point and the lift when changing stud lengths/ diameters or with any alterations to the front end arrangement.

Other useful information including stud welding techniques, weld testing and inspection can also be found in the controller operating guide.

PLEASE NOTE. Information contained in this operating guide is intended to assist in setting up and using the pistol. All the suggested settings are intended as a starting point only. Fine tuning the settings to achieve the most satisfactory results is essential and is the responsibility of the user of the pistol.

EXPLODED DIAGRAMS & PARTS LISTINGS

SEE PAGE 12
FOR FRONT AND
REAR END
PARTS

SEE PAGE 16
FOR SHAFT
ASSEMBLY
PARTS

SEE PAGE 15
FOR BARREL
ASSEMBLY
PARTS

SEE PAGE 13
FOR SPLIT
BODY PARTS

SEE PAGE 14
FOR PISTOL
GRIP PARTS

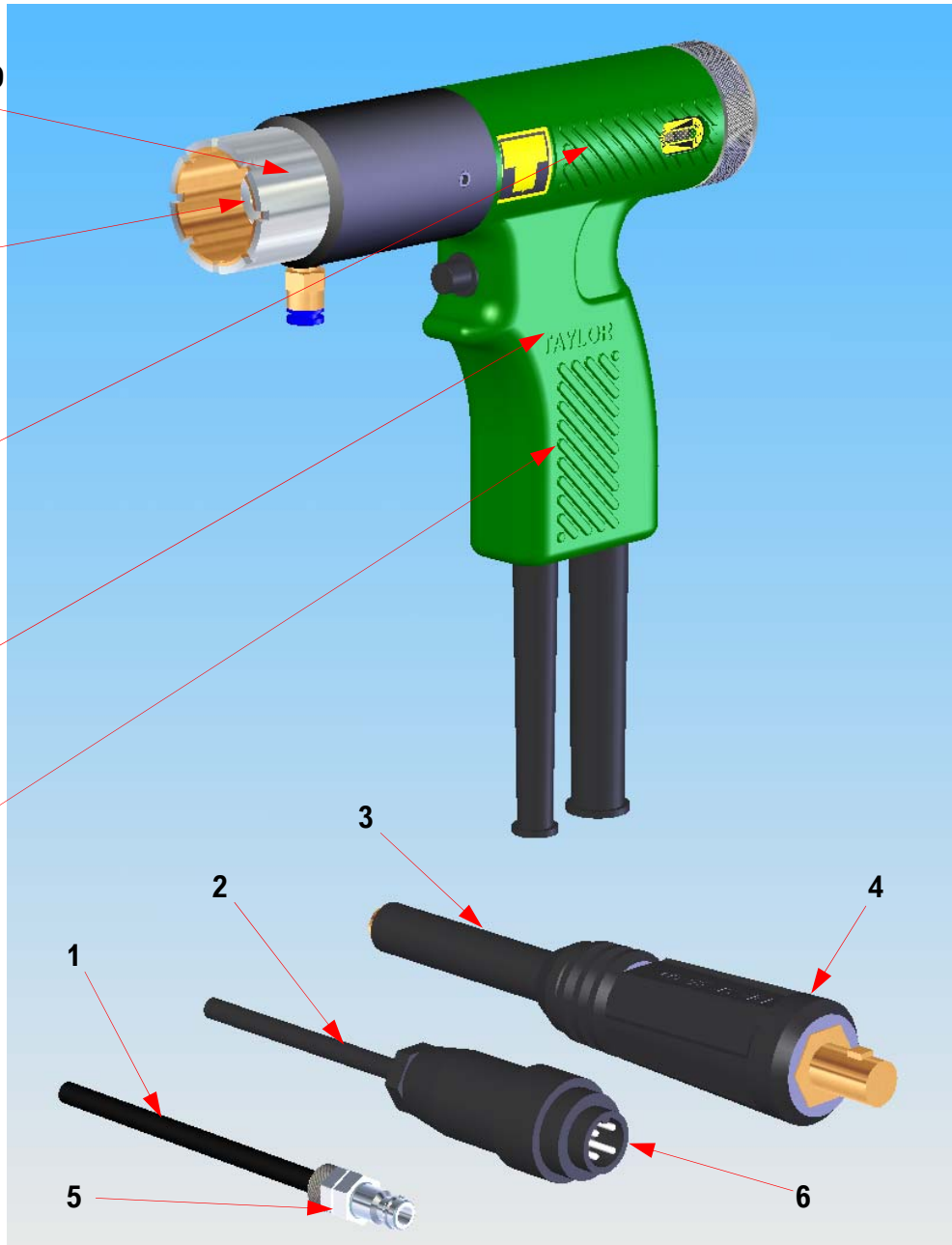

ITEM	No. OFF	PART No.	DESCRIPTION
1	4½	71-200-044	GAS PIPE
2	4½	71-300-009	CONTROL CABLE
3	4	71-300-002	WELDING CABLE
4	1	81-101-051	WELDING PLUG
5	1	71-200-067	GAS PLUG
6	1	71-101-030	CONTROL PLUG
7	9	71-101-032	CABLE TIE (NOT SHOWN)

EXPLODED DIAGRAMS & PARTS LISTINGS

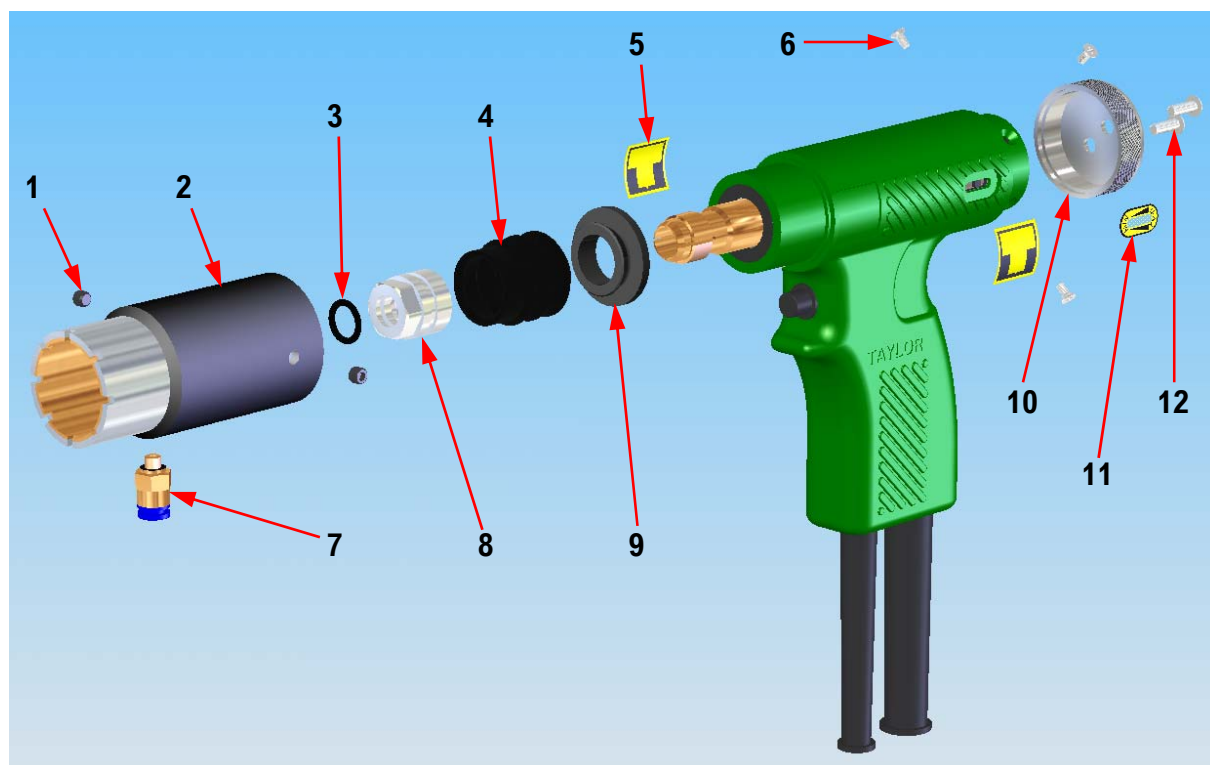

ITEM	No. OFF	PART No.	DESCRIPTION
1	2	Z400-05-005	GRUB SCREW
2	1	89-101-535	30 mm GAS NOSE CONE
3	1	71-101-001	“O” RING
4	1	71-101-003	RUBBER BELLOWS
5	2	71-101-050	DECAL STICKER
6	4	Z205-03-006	SCREW
7	1	KQH06-M5	GAS FITTING
8	1	71-101-002	CHUCK NUT
9	1	71-101-004	BELLOWS RETAINER
10	1	71-102-067	REAR END CAP
11	1	71-102-070	LIFT INDICATION DECAL
12	2	Z110-04-012	SCREW



EXPLODED DIAGRAMS & PARTS LISTINGS

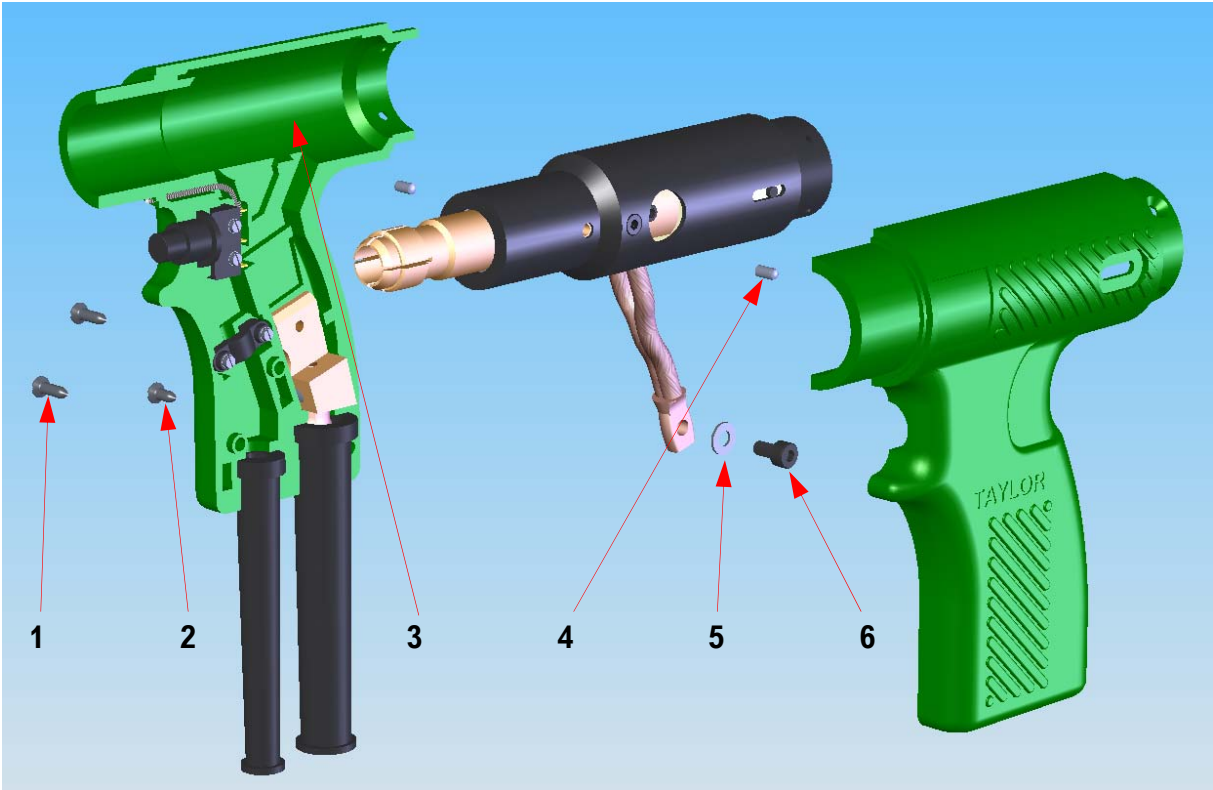

ITEM	No. OFF	PART No.	DESCRIPTION
1	2	Z245-06-016	SCREW
2	1	Z245-06-012	SCREW
3	1	71-102-069	PISTOL BODY (PAIR - GREEN)
4	2	71-101-007	PIN
5	1	Z600-04-000	WASHER
12	1	Z100-04-010	SCREW



EXPLODED DIAGRAMS & PARTS LISTINGS

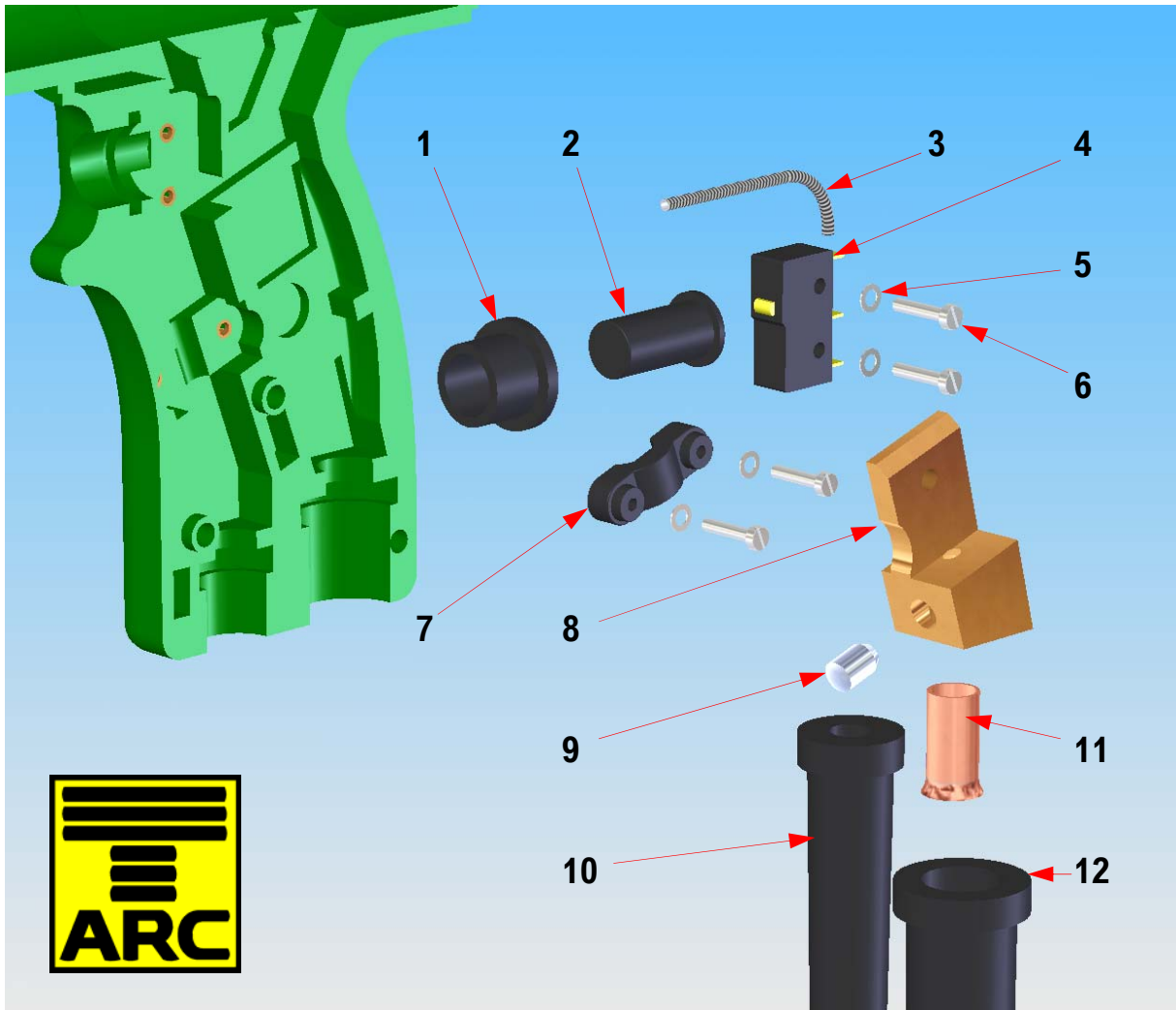

ITEM	No. OFF	PART No.	DESCRIPTION
1	1	71-101-036	PUSH-BUTTON BUSH
2	1	71-101-035	PUSH-BUTTON
3	1	71-101-009	CONTACT
4	1	71-101-028	TRIGGER MICROSWITCH
5	4	Z600-02-000	WASHER
6	4	Z220-02-010	SCREW
7	1	71-101-027	CORD GRIP
8	1	71-102-030	CABLE TERMINATOR
9	1	71-102-029	CABLE DOWEL
10	1	71-101-033	CONTROL CABLE SLEEVE
11	1	71-101-042	FERRULE
12	1	71-101-034	WELD CABLE SLEEVE

EXPLODED DIAGRAMS & PARTS LISTINGS

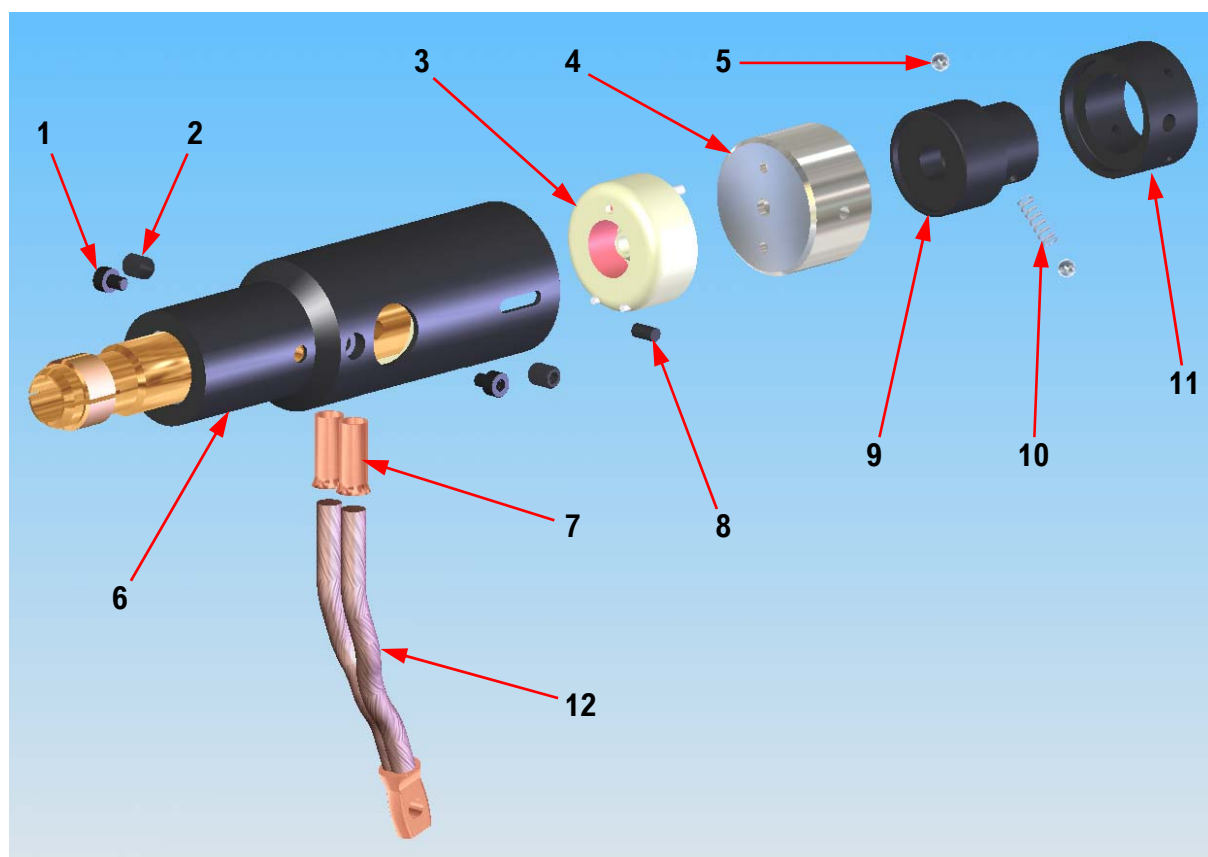

ITEM	No. OFF	PART No.	DESCRIPTION
1	2	Z100-03-005	SCREW
2	2	Z410-05-008	GRUB SCREW
3	1	71-102-056	SOLENOID COIL
4	1	71-102-064	COIL MOUNTING CUP
5	2	81-101-082	DETENT BALL
6	1	71-102-068	LINER SLEEVE
7	2	71-101-041	FERRULE
8	1	71-102-075	INDICATOR PIN
9	1	71-102-065	COIL ADJUSTER
10	1	71-102-073	DETENT SPRING
11	1	71-102-066	REAR BUSH
12	1	71-102-058	BRAID ASSEMBLY



EXPLODED DIAGRAMS & PARTS LISTINGS

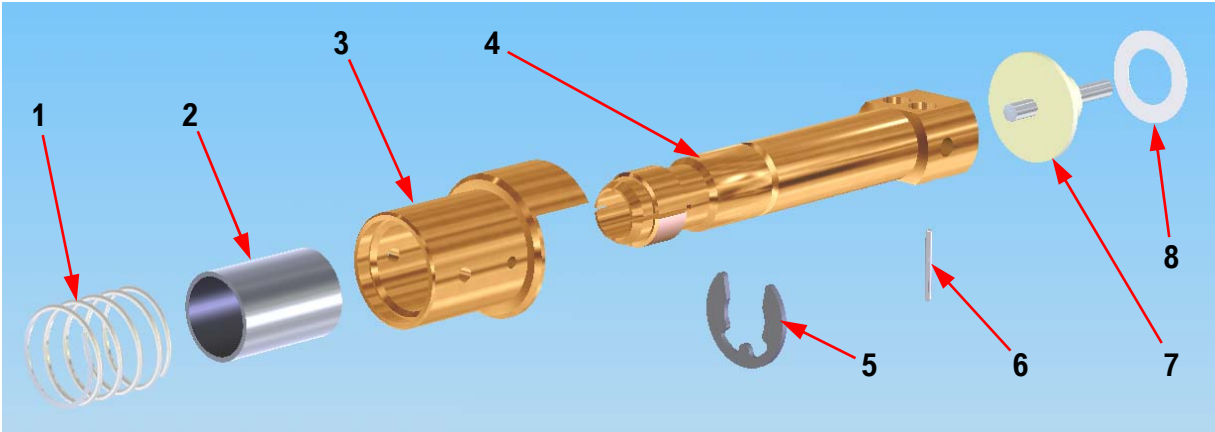

NOTE! ITEMS 7 & 8 CAN ONLY BE OBTAINED AS PART OF THE SOLENOID COIL 71-102-056 (SEE PREVIOUS PAGE ITEM 3).

ITEM	No. OFF	PART No.	DESCRIPTION
1	1	71-102-074	SPRING
2	1	71-102-071	BEARING BUSH
3	1	71-102-062	BEARING HOUSING
4	1	71-102-061	WELD SHAFT
5	1	71-101-011	CIRCLIP
6	1	71-102-015	SPIROLL PIN
7	1	SEE NOTE	POLE PIECE
8	1	SEE NOTE	HYSTERESIS WASHER



ACCESSORIES

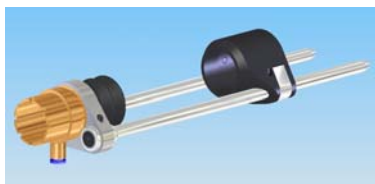
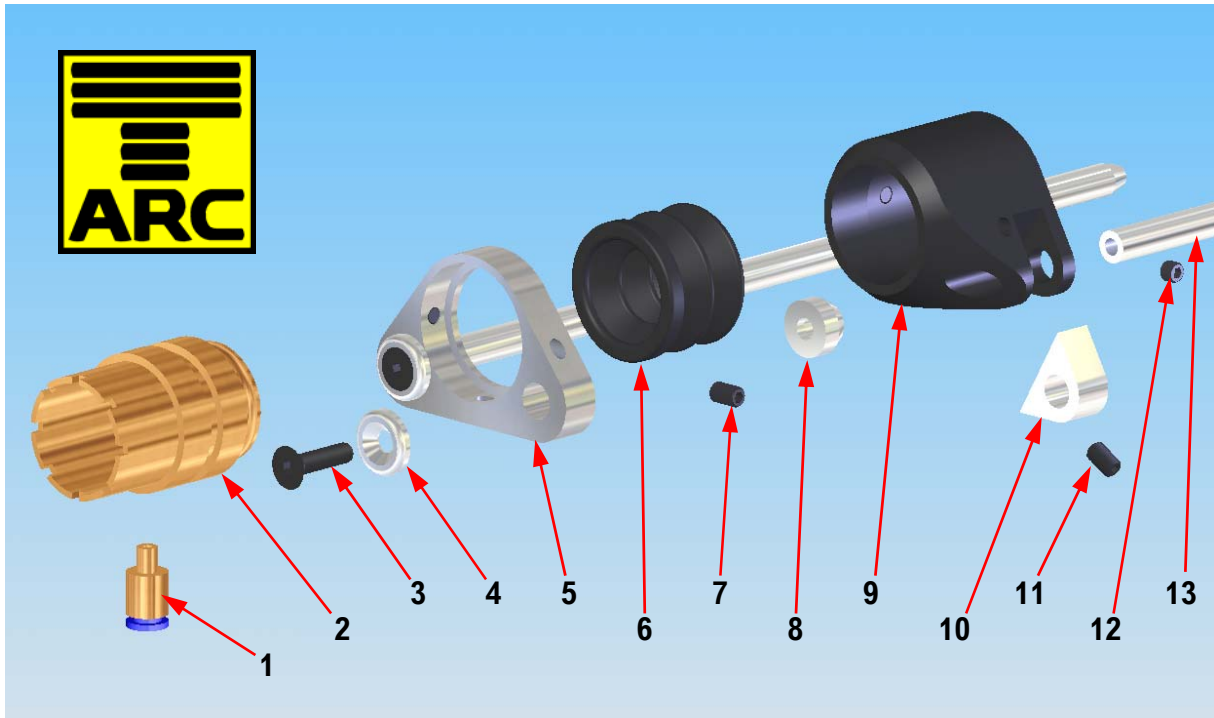

COMPLETE ASSEMBLY PART NUMBERS :

Ø30 mm : 89-101-315
 Ø35 mm : 89-101-316

ITEM	No. OFF	PART No.	DESCRIPTION
1	1	KQH06-M5	PIPE FITTING
2	1	89-101-268	Ø30 mm GAS NOSE CONE
or	1	89-101-269	Ø35 mm GAS NOSE CONE
3	2	Z120-05-025	SCREW
4	2	81-101-003	FOOT WASHER - FRONT
5	1	89-101-251	FOOT ADAPTOR
6	1	89-101-243	GAS RETENTION BELLOWS - Ø7
or	1	89-101-244	GAS RETENTION BELLOWS - Ø10
7	2	Z420-05-006	GRUB SCREW
8	2	81-101-001	FOOT WASHER - REAR
9	1	79-101-141	FRONT END CAP
10	2	79-101-142	PIVOTAL GRIP INSERT
11	2	Z400-05-006	GRUB SCREW
12	2	Z400-05-004	GRUB SCREW
13	2	81-101-004	LEG

ACCESSORIES

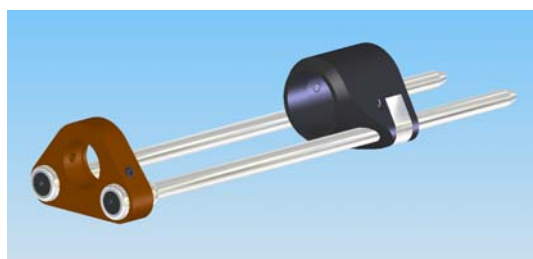
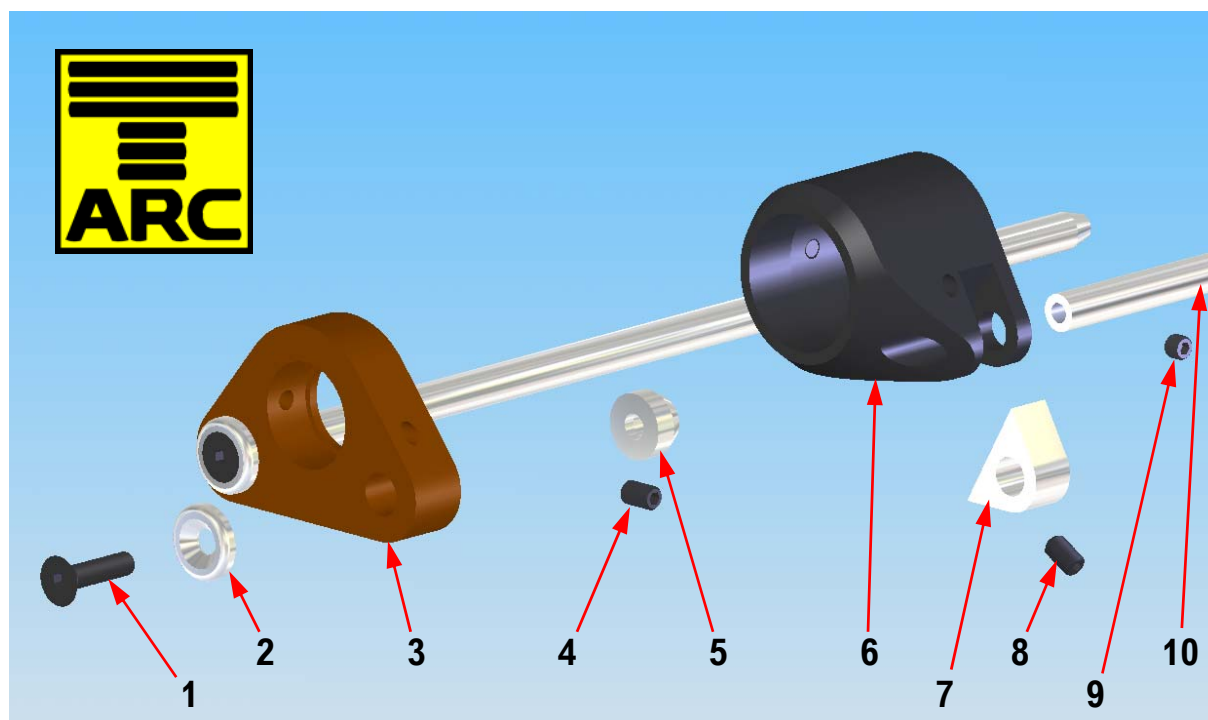

COMPLETE ASSEMBLY
PART NUMBER : 89-101-317

ITEM	No. OFF	PART No.	DESCRIPTION
1	2	Z120-05-025	SCREW
2	2	81-101-003	FOOT WASHER - FRONT
3	1	89-101-253	FOOT ADAPTOR
4	2	Z420-05-006	GRUB SCREW
5	2	81-101-001	FOOT WASHER - REAR
6	1	79-101-141	FRONT END CAP
7	2	79-101-142	PIVOTAL GRIP INSERT
8	2	Z400-05-006	GRUB SCREW
9	2	Z400-05-004	GRUB SCREW
10	2	81-101-004	LEG

ACCESSORIES

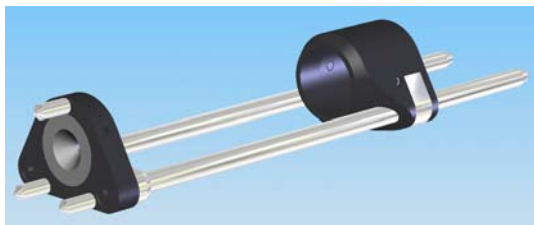
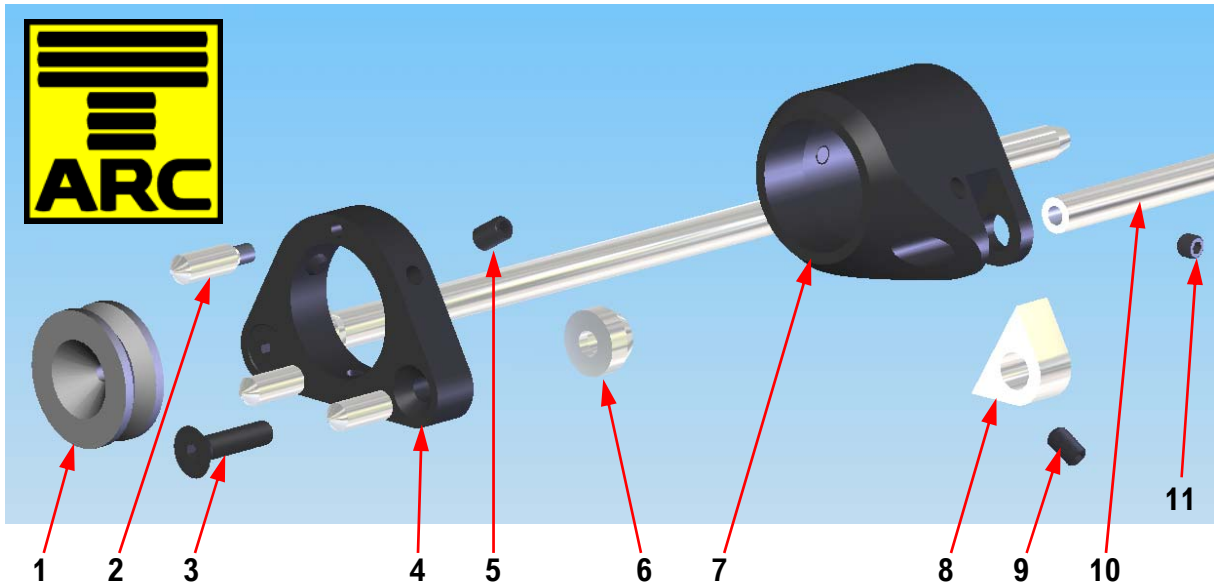

COMPLETE ASSEMBLY
PART NUMBER : 89-101-321

ITEM	No. OFF	PART No.	DESCRIPTION
1	1	79-101-144	NAIL GUIDE
2	3	79-101-106	SMALL TRIPOD FOOT
3	2	Z120-05-020	SCREW
4	1	79-101-143	FOOT ADAPTOR
5	3	Z410-05-008	GRUB SCREW
6	2	81-101-001	FOOT WASHER - REAR
7	1	79-101-141	FRONT END CAP
8	2	79-101-142	PIVOTAL GRIP INSERT
9	2	Z400-05-006	GRUB SCREW
10	2	81-101-004	LEG
11	2	Z400-05-005	GRUB SCREW

ACCESSORIES

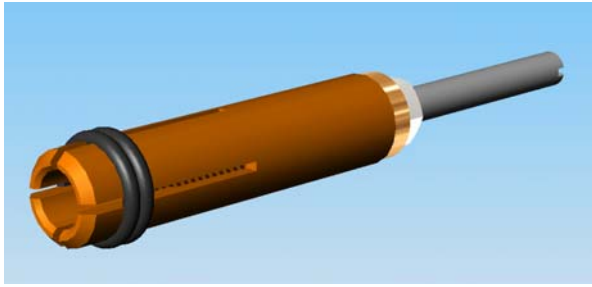

CHUCK SIZE	PART NUMBER
Ø3 mm	79-101-003
Ø4 mm	79-101-004
Ø5 mm	79-101-005
Ø6 mm	79-101-006
Ø7.1 mm	79-101-007
Ø8 mm	79-101-008

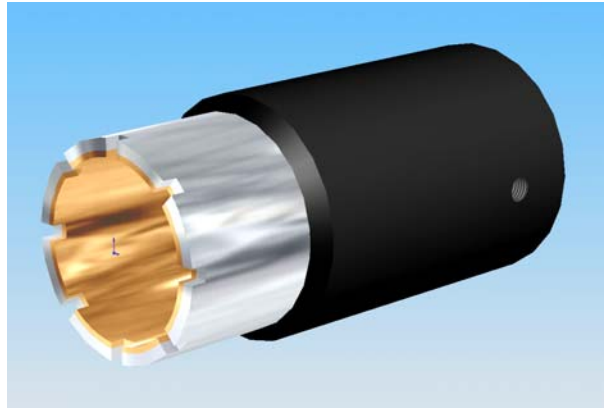

ONE PIECE GAS CONE	PART NUMBER
Ø25 mm	89-101-536
Ø30 mm	89-101-530
Ø35 mm	89-101-535

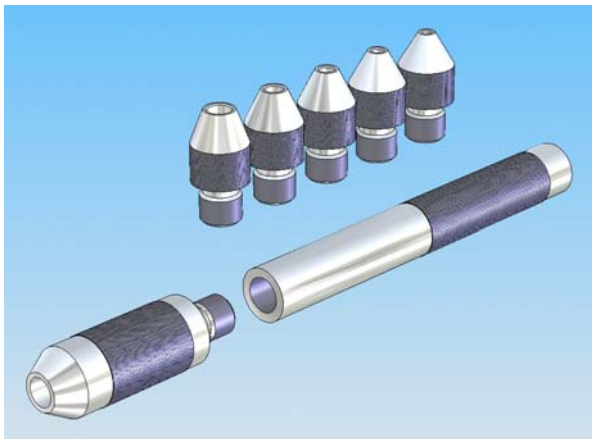

ITEM	PART NUMBER
BENDING BAR	79-101-121
M3 NOZZLE	79-101-123
M4 NOZZLE	79-101-124
M5 NOZZLE	79-101-125
M6 NOZZLE	79-101-126
M8 NOZZLE	79-101-127
M10 NOZZLE	79-101-128
COMPLETE SET	79-101-120

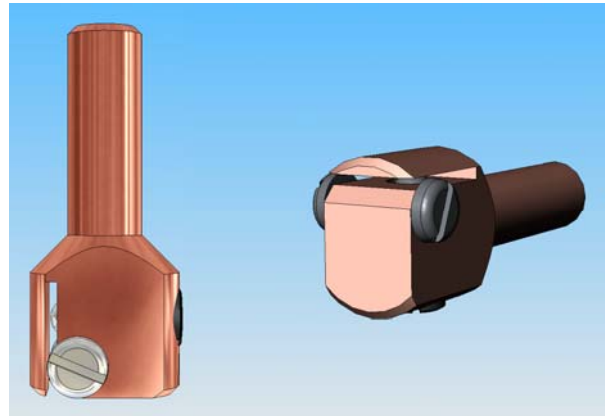

LARGE BRACKET CHUCK	79-101-231
EARTH TAG CHUCK	79-101-019

PLEASE NOTE. MANY OTHER CHUCK SIZES ARE AVAILABLE. PLEASE CHECK WITH US IF THE SIZE YOU WANT IS NOT LISTED HERE.



EC DECLARATION



TAYLOR STUDWELDING SYSTEMS LIMITED
COMMERCIAL ROAD
DEWSBURY
WEST YORKSHIRE
ENGLAND
WF13 2BD

TEL : +44 (0)1924 452123
FAX : +44 (0)1924 430059
EMAIL : sales@taylor-studwelding.com

This is to certify that the machinery listed below is designed and manufactured in conformance with all applicable health and safety regulations. This statement is invalid if any modifications are carried out on the machinery without the prior written approval of Taylor Studwelding Systems Ltd.

DESCRIPTION OF MACHINE	:	Drawn Arc Studwelding Pistol
TYPE	:	DA8
PART NUMBER	:	99-101-030

Applicable EC guidelines and corresponding standards:

- Low voltage guideline 73/23/EEC:
EN60204-1 Safety of machinery - Electrical equipment of machines.
- EMC guidelines 89/336/EEC (electromagnetic compatibility):
EN50081 Electromagnetic compatibility - Generic emission standard
EN50082 Electromagnetic compatibility - Generic immunity standard
EN50199 Electromagnetic compatibility (EMC) Product standard for Arc welding equipment
- Machine guidelines 89/392/EEC
EN60974-1 Arc welding equipment : Electromagnetic compatibility (EMC) requirements

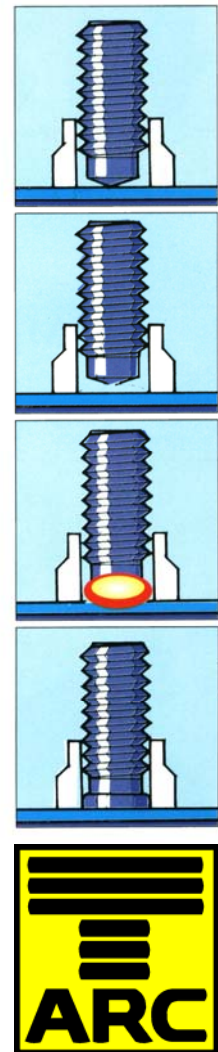

SIGNED

DAVID TAYLOR
MANAGING DIRECTOR

A TAYLORMADE DRAWN ARC STUDWELDING PISTOL